

CADENAS DE RODILLOS SIMPLE DIN 8187 SERIE EUROPEA

Simple roller chains DIN 8187 european series

Chaînes à rouleaux simple DIN 8187 série européenne

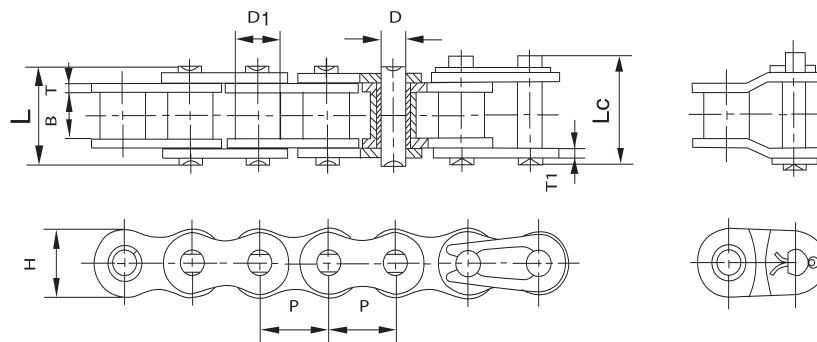

Cadenas de rodillos simples - Serie B

Simple roller chains - B Series

Chaînes à rouleaux simple - Série B

Referencia Reference Référence	Paso Pitch Pas	Ancho interior Inner width Largeur intérieur	Ø Rodillo Roller Rouleau	Ø Eje Pin Axe	Longitud eje Pin length Longueur axe		Ancho malla Plate width Largeur plaques	Espesor malla Plate thickness Épaisseur plaques	Carga de rotura Breaking load Charge rupture	Peso por metro Weight per meter Poids par mètre
DIN/ISO	P mm	B min mm	D1 max mm	D max mm	L max mm	Lc max mm	H max mm	T/T1 max mm	Q min KN	q Kg/m
04B-1	6,000	2,80	4,00	1,85	6,80	7,8	5,00	0,60	3,0	0,11
05B-1	8,000	3,00	5,00	2,31	8,20	8,9	7,10	0,80	5,0	0,20
*06B-1	9,525	5,72	6,35	3,28	13,15	14,1	8,20	1,30	9,0	0,41
081-1	12,700	3,30	7,75	3,65	10,20	11,70	9,91	0,95	8,2	0,30
083-1	12,700	4,88	7,75	4,09	12,90	14,40	10,30	1,20	12,0	0,42
08B-1	12,700	7,75	8,51	4,45	16,70	18,2	11,80	1,60	18,0	0,69
10B-1	15,875	9,65	10,16	5,08	19,50	20,9	14,70	1,70	22,4	0,93
12B-1	19,050	11,68	12,07	5,72	22,50	24,2	16,00	1,85	29,0	1,15
16B-1	25,400	17,02	15,88	8,28	36,10	37,4	21,00	4,15/3,1	60,0	2,71
20B-1	31,750	19,56	19,05	10,19	41,30	45,0	26,40	4,5/3,5	95,0	3,70
24B-1	38,100	25,40	25,40	14,63	53,40	57,8	33,20	6,0/4,8	160,0	7,10
28B-1	44,450	30,99	27,94	15,90	65,10	69,5	36,70	7,5/6,0	200,0	8,50
32B-1	50,800	30,99	29,21	17,81	66,00	71,0	42,00	7,0/6,0	250,0	10,25
40B-1	63,500	38,10	39,37	22,89	82,20	89,2	52,96	8,5/8,0	355,0	16,35
48B-1	76,200	45,72	48,26	29,24	99,10	107,0	63,80	12/10	560,0	25,00
56B-1	88,900	53,34	53,98	34,32	114,60	123,00	77,80	13,5/12,0	850,00	35,78
64B-1	101,600	60,96	63,50	39,40	130,00	138,50	90,17	15,0/13,0	1.100,00	46,00
72B-1	114,300	68,58	72,39	44,48	147,40	156,40	103,60	17,0/15,0	1.400,00	60,80

* Malla recta / Straight plates / Plaques droites

CADENAS DE RODILLOS DOBLE DIN 8187 SERIE EUROPEA

Double roller chains DIN 8187 european series
Chaînes à rouleaux doubles DIN 8187 série européenne

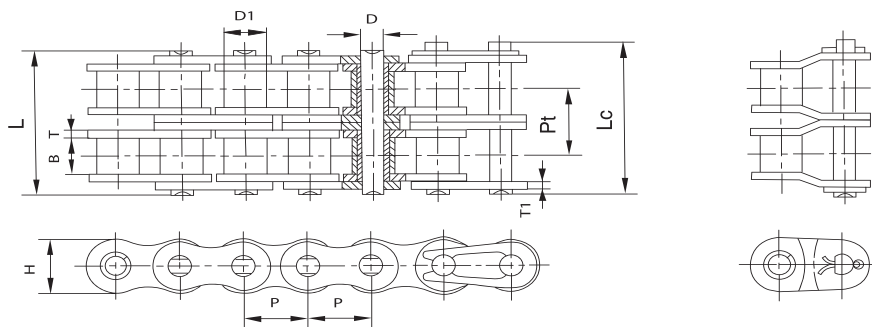

Cadenas de rodillos dobles - serie B

Double roller chains - B series
Chaînes à rouleaux doubles - Série B

Referencia Reference Référence	Paso Pitch Pas	Ancho interior Inner width Largeur intérieur	Ø Rodillo Roller Rouleau	Ø Eje Pin Axe	Longitud eje Pin length Longueur axe	Ancho malla Plate width Largeur plaques	Espesor malla Plate thickness Épaisseur plaques	Paso transversal Transverse pitch Pas transversal	Carga de rotura Breaking load Charge rupture	Peso por metro Weight per meter Poids par mètre	
DIN/ISO	P	B min	D1 max	D max	L max	Lc max	H max	T/T1 max	Pt	Q min	q
	mm	mm	mm	mm	mm	mm	mm	mm	mm	KN	Kg/m
05B-2	8,000	3,00	5,00	2,31	13,9	14,5	7,10	0,80	5,64	7,8	0,33
*06B-2	9,525	5,72	6,35	3,28	23,4	24,4	8,20	1,30	10,24	16,9	0,77
08B-2	12,700	7,75	8,51	4,45	31,2	32,2	11,80	1,60	13,92	32,0	1,34
10B-2	15,875	9,65	10,16	5,08	36,1	37,5	14,70	1,70	16,59	44,5	1,84
12B-2	19,050	11,68	12,07	5,72	42,0	43,6	16,00	1,85	19,46	57,8	2,31
16B-2	25,400	17,02	15,88	8,28	68,0	69,3	21,00	4,15/3,1	31,88	106,0	5,42
20B-2	31,750	19,56	19,05	10,19	77,8	81,5	26,40	4,5/3,5	36,45	170,0	7,20
24B-2	38,100	25,40	25,40	14,63	101,7	106,2	33,20	6,0/4,8	48,36	280,0	13,40
28B-2	44,450	30,99	27,94	15,90	124,6	129,1	36,70	7,5/6,0	59,56	360,0	16,60
32B-2	50,800	30,99	29,21	17,81	124,6	129,6	42,00	7,0/6,0	58,55	450,0	21,00
40B-2	63,500	38,10	39,37	22,89	154,5	161,5	52,96	8,5/8,0	72,29	630,0	32,00
48B-2	76,200	45,72	48,26	29,24	190,4	198,2	63,80	12/10	91,21	1.000,0	50,00
56B-2	88,900	53,34	53,98	34,32	221,20	229,60	77,80	13,5/12,0	106,60	1.600,00	71,48
64B-2	101,600	60,96	63,50	39,40	249,90	258,40	90,17	15,0/13,0	119,89	2.000,00	91,00
72B-2	114,300	68,58	72,39	44,48	283,70	292,70	103,60	17,0/15,0	136,27	2.500,00	120,40

* Malla recta / Straight plates / Plaques droites

CADENAS DE RODILLOS TRIPLE DIN 8187 SERIE EUROPEA

Triple roller chains DIN 8187 european series

Chaînes à rouleaux triples DIN 8187 série européenne

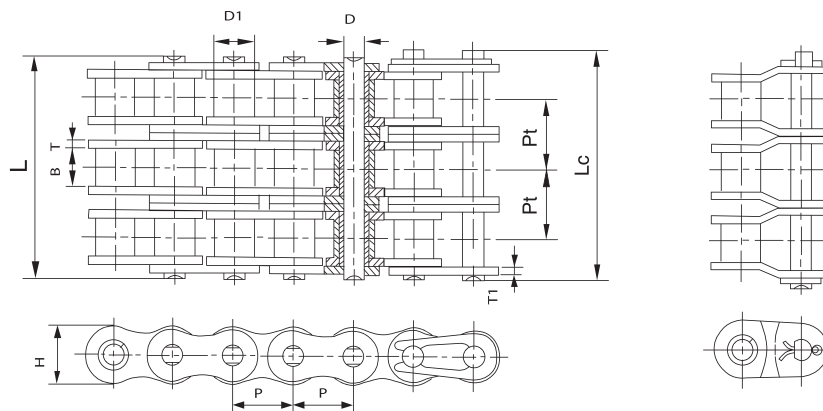

Cadenas de rodillos triples - Serie B

Triple roller chains - B Series

Chaînes à rouleaux triples - Série B

Referencia Reference Référence	Paso Pitch Pas	Ancho interior Inner width Largeur intérieure	Ø Rodillo Roller Rouleau	Ø Eje Pin Axe	Longitud eje Pin length Longueur axe	Ancho malla Plate width Largeur plaques	Espesor malla Plate thickness Épaisseur plaques	Paso transversal Transverse pitch Pas transversal	Carga de rotura Breaking load Charge rupture	Peso por metro Weight per meter Poids par mètre	
DIN/ISO	P	B min	D1 max	D max	L max	Lc max	H max	T/T1 max	Pt	Q min	q
	mm	mm	mm	mm	mm	mm	mm	mm	mm	KN	Kg/m
05B-3	8,000	3,00	5,00	2,31	19,5	20,2	7,10	0,80	5,64	11,1	0,48
*06B-3	9,525	5,72	6,35	3,28	33,5	34,6	8,20	1,30	10,24	24,9	1,16
08B-3	12,700	7,75	8,51	4,45	45,1	46,1	11,80	1,60	13,92	47,5	2,03
10B-3	15,875	9,65	10,16	5,08	52,7	54,1	14,70	1,70	16,59	66,7	2,77
12B-3	19,050	11,68	12,07	5,72	61,5	63,1	16,00	1,85	19,46	86,7	3,46
16B-3	25,400	17,02	15,88	8,28	99,8	101,2	21,00	4,15/3,1	31,88	160,0	8,13
20B-3	31,750	19,56	19,05	10,19	114,2	117,9	26,40	4,5/3,5	36,45	250,0	10,82
24B-3	38,100	25,40	25,40	14,63	150,1	154,6	33,20	6,0/4,8	48,36	425,0	20,10
28B-3	44,450	30,99	27,94	15,90	184,2	188,7	36,70	7,5/6,0	59,56	530,0	24,92
32B-3	50,800	30,99	29,21	17,81	183,2	188,2	42,00	7,0/6,0	58,55	670,0	31,56
40B-3	63,500	38,10	39,37	22,89	226,8	233,8	52,96	8,5/8,0	72,29	950,0	48,10
48B-3	76,200	45,72	48,26	29,24	281,6	289,4	63,80	12/10	91,21	1.500,0	75,00
56B-3	88,900	53,34	53,98	34,32	327,80	336,20	77,80	13,5/12,0	106,60	2.240,00	107,18
64B-3	101,600	60,96	63,50	39,40	369,80	378,30	90,17	15,0/13,0	119,89	3.000,00	136,00
72B-3	114,300	68,58	72,39	44,48	420,00	429,00	103,60	17,0/15,0	136,27	3.750,00	180,00

* Malla recta / Straight plates / Plaques droites